

JUMO GmbH & Co. KG
 Delivery address: Mackenrodtstraße 14
 36039 Fulda, Germany
 Postal address: 36035 Fulda, Germany
 Phone: +49 661 6003-0
 Fax: +49 661 6003-607
 E-mail: mail@jumo.net
 Internet: www.jumo.net

JUMO Instrument Co. Ltd.
 JUMO House
 Temple Bank, Riverway
 Harlow, Essex CM20 2DY, UK
 Phone: +44 1279 635533
 Fax: +44 1279 635262
 E-mail: sales@jumo.co.uk
 Internet: www.jumo.co.uk

JUMO Process Control, Inc.
 6733 Myers Road
 East Syracuse, NY 13057, USA
 Phone: 315-437-5866
 1-800-554-5866
 Fax: 315-437-5860
 E-mail: info.us@jumo.net
 Internet: www.jumousa.com



JUMO DICON touch Two-channel process and program controller with paperless recorder and touchscreen

Brief description

The DICON touch is a two-channel universal process and program controller that displays information on a vibrant screen. The device is easy to operate via a touchscreen. Both control channels use the tried-and-tested JUMO control algorithm with two possible optimization options. These enable a simple and highly-accurate startup. It also enables multiple zone control, cascade control, or other complex control tasks.

The block diagram below illustrates the various different hardware options offered by the modular hardware concept. Four analog universal inputs and up to eight external inputs can record a variety of physical measured values with high precision. The actuators can be controlled directly in the device with either an analog or digital setup. These can be expanded further through external digital outputs. Interfaces such as Modbus (master/slave), PROFIBUS, or Ethernet with Web server can be used for the communication with higher-order systems.

To ensure secure process operation, the device has a password-protected user administration with individual assignment of rights for different levels or control commands. Screen masks for controllers, program generators, recording, and for overview screens are ready-made and available. An individual process screen can be created using the configuration software. Using the extra-code recording function, important analog and digital process values can be saved so that they are tamper-proof, so that they can be graphically visualized, and so that they can be exported via interface or USB stick in a tamper-proof fashion to the PC.

The configuration software ensures that the process controller can be easily programmed, that math or logical coherences can be described, and that customer-specific linearizations can be created. In addition, tools for simulating external signals or control paths are included. These tools can also record for the duration of the startup.

A comprehensive alarm and limit-value concept as well as a flexible digital signal administration complete the "all-in-one" device.



Type 703571/...

Block diagram

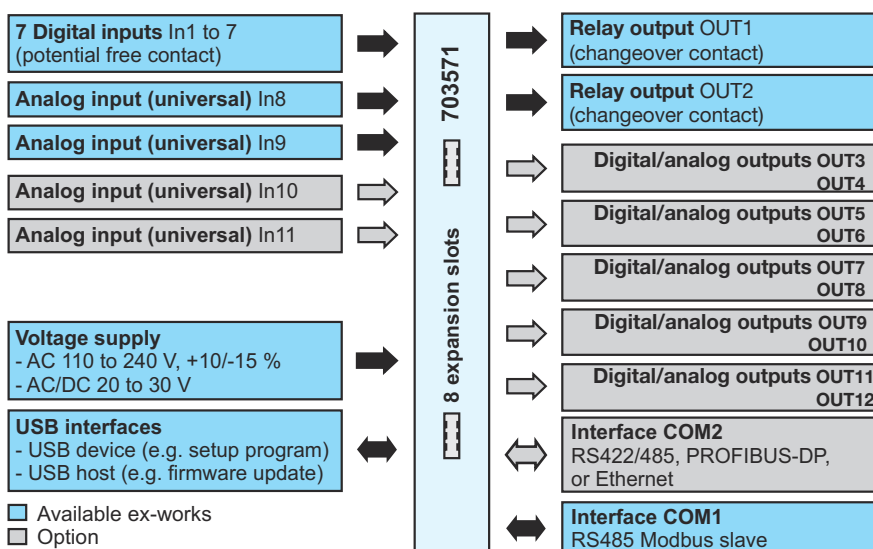

Special features

- Vibrant 3.5-inch color screen, with 320 × 240 pixels and 256 colors
- Easy-to-use program entry and program control
- Interfaces: USB host, USB device, Modbus (master/slave), PROFIBUS-DP, and Ethernet
- Integrated paperless recorder with tamper-proof data storage (extra code)
- Individual process-screen display with configurable edit boxes
- Math and logic functions
- Flexible through modular hardware
- Password-protected user administration
- Five-digit analog value display
- Individual operator level
- Control loop and output value monitoring
- Integrated timer and time switch Service and operating hours counter
- Web server for online visualization via a Web browser
- Alarm transmission by email
- Protection type on the front IP66
- cUL, GL, DIN EN14597 approval applied for

Approvals / approval marks (see "Technical data")

JUMO GmbH & Co. KG

Delivery address: Mackenrodtstraße 14
36039 Fulda, Germany
Postal address: 36035 Fulda, Germany
Phone: +49 661 6003-0
Fax: +49 661 6003-607
E-mail: mail@jumo.net
Internet: www.jumo.net

JUMO Instrument Co. Ltd.

JUMO House
Temple Bank, Riverway
Harlow, Essex CM20 2DY, UK
Phone: +44 1279 635533
Fax: +44 1279 635262
E-mail: sales@jumo.co.uk
Internet: www.jumo.co.uk

JUMO Process Control, Inc.

6733 Myers Road
East Syracuse, NY 13057, USA
Phone: 315-437-5866
1-800-554-5866
Fax: 315-437-5860
E-mail: info.us@jumo.net
Internet: www.jumousa.com



Description

Controller types

The controller can be configured as a two-state controller, three-state controller, three-state modulating controller, continuous controller, or continuous controller with integrated position controller. The cycle time is 150 ms.

Parameter blocks

Four parameter blocks can be assigned to each controller. Each parameter block has 15 parameters. The controller structures P, I, PD, PI, and PID can be adjusted.

Self-optimization

Self-optimization also makes it possible for the controller to be matched to the control loop by a user who is not a control technology expert. During this, the reaction of the control path to the variable change is evaluated. Two different optimization processes are available. The oscillation method is preset as standard method in the controller.

User level

Up to 25 parameters of any type from the configuration or parameter level can be included in this level. These parameters, for example, often need to be changed or made available to operating personnel (see "User administration").

User administration

Password-protected user administration guarantees safe process operation. This function allows the individual assignment of rights, enabling four users to access different levels and control commands.

Setpoint values

Up to four setpoint values can be entered for each controller channel. Changeover of these setpoint values is controlled by two binary-coded digital signals. However, the setpoint values for both controllers can also be specified as an external setpoint selection via an additional analog input or an interface.

Program controller (extra code)

Ten programs with 50 sections can be programmed in the program controller. Each program can be assigned a program name and an icon.

Two setpoint values, section run times, control contacts, tolerance bands, cycles, and parameter blocks can be assigned in each program section.

The tolerance band monitoring function monitors the actual value in an adjustable band around the setpoint value. The output signal of the tolerance band monitoring function can, for example, also be used to stop the program.

Ramp function

The ramp function allows a continuous change of the setpoint value to the ramp end value (setpoint selection) for each controller chan-

nel. After power ON, the ramp starts at the current value. The slope of the ramp is determined via different gradients for a rising and falling ramp. The ramp starts at the time the setpoint value is changed or at the same time as a digital signal. The ramp function can be controlled by digital signals or via the functional level.

Limit value monitoring

16 limit value monitoring functions are available – each has eight selectable alarm functions AF1 to AF8. The limit value can be fixed or dependent on another process variable (setpoint value).

A wide range of functions can be realized by means of additional parameters such as the location and value of the switching differential, on and off delay, pulse function, type of acknowledgment, and startup alarm suppression. The startup alarm suppression function, for example, can be used to prevent the limit value monitoring function from being triggered during the startup phase of a process.

Math and logic function (extra code)

The math and logic module allows analog and/or digital signals to be operated. The following math formulas are available to the operators: +, -, *, /, SQRT(), MIN(), MAX(), SIN(), COS(), TAN(), **, EXP(), ABS(), INT(), FRC(), LOG(), LN(), humidity and moving average, as well as !, &, |, ^, and (and).

Difference, ratio, and humidity can also be configured on the device without extra code.

Analog inputs

The analog inputs (maximum of four) are universal measuring inputs for RTD temperature probes, thermocouples, resistors (resistance transmitters, potentiometers), and standard signals (current, voltage). Linearizations for over 20 common measuring probes are saved. A measurement offset or a fine adjustment can be carried out to compensate for machine-specific deviations.

Due to the measuring circuit monitoring function, out of range (too high or too low), probe/cable break, and probe/cable short circuit are detected depending on the type of measuring element so that the system is switched to a safe operating state (configurable) in the event of a fault.

Customer-specific linearization

A customer-specific linearization is additionally possible. Programming is carried out with the aid of the setup program, using a value table with 40 pairs of values or a fourth-order polynomial as a formula.

Analog outputs

Up to five analog outputs can be realized in the device. They can be used, for example, as controller outputs, setpoint value outputs, to output results of the math formulas, or as current value outputs. The signals are freely scalable.

Digital inputs

The signals of the seven standard digital inputs (potential-free contacts) can be used to initiate different internal functions (e.g. switching the parameter block, starting self-optimization, or acknowledging limit value monitoring).

Digital outputs

Up to 12 digital outputs can be realized in the device (see block diagram). They can be used as, for example, controller outputs, limit value monitoring signals, results of logic operations, or for programmer signals, etc.

External inputs

Eight external analog inputs and eight external digital inputs can each be read via an interface. The unit, range limits, and alarms can be adjusted for the external analog inputs.

Timer

Two timer functions are provided as standard. They can be used as relative timers or as weekly time switches (linked to the real-time clock).

Binary control signals

There are eight binary control signals with different functions (OR operation, BCD operation, delay, inversion). The results are also available to control internal functions or they can be output to digital outputs.

Web server (online visualization)

This function is available if the Ethernet interface is installed in expansion slot COM2. All displays in the device control ring are automatically accessible without configuration.

Alarm transmission by email

An email alarm can be sent to up to three addresses simultaneously via a mail server. Up to five alarm messages can be configured; the sending process is controlled by digital signals. There are five different alarm messages for this. These are linked to specific digital signals from the device.

Recording function (extra code)

Four analog channels and three digital channels can be recorded. They appear as line recorders with a time stamp. The recorder image is always present. It is only possible to use the "history" function and to extract the registry data via PCC, PCA by means of the extra code 213 recording function.

JUMO GmbH & Co. KG

Delivery address: Mackenrodtstraße 14
36039 Fulda, Germany
Postal address: 36035 Fulda, Germany
Phone: +49 661 6003-0
Fax: +49 661 6003-607
E-mail: mail@jumo.net
Internet: www.jumo.net

JUMO Instrument Co. Ltd.

JUMO House
Temple Bank, Riverway
Harlow, Essex CM20 2DY, UK
Phone: +44 1279 635533
Fax: +44 1279 635262
E-mail: sales@jumo.co.uk
Internet: www.jumo.co.uk

JUMO Process Control, Inc.

6733 Myers Road
East Syracuse, NY 13057, USA
Phone: 315-437-5866
1-800-554-5866
Fax: 315-437-5860
E-mail: info.us@jumo.net
Internet: www.jumousa.com

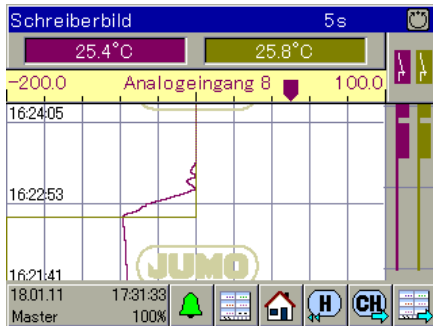
**Setup program**

The setup program makes the controller easy to configure and parameterize using a PC. Data sets can thus be created, edited, and transferred to the controller – and can be extracted from there. The data can be saved and printed out. The setup program supports multiple languages, including English, German and French.

ER8 external relay module (accessories)

By connecting two ER8 external relay modules, eight relay or digital outputs (12 V/20 mA) can be added to the device in each case. They are controlled via an RS422/RS485 interface. The ER8s can be mounted on a DIN rail and must be configured using the setup program. Two ER8s can be connected.



Display and control elements

The DICON touch has no control elements. Instead, it can either be operated via a resistive touchscreen, which responds to finger pressure, or by using conventional pens with a rounded plastic tip.

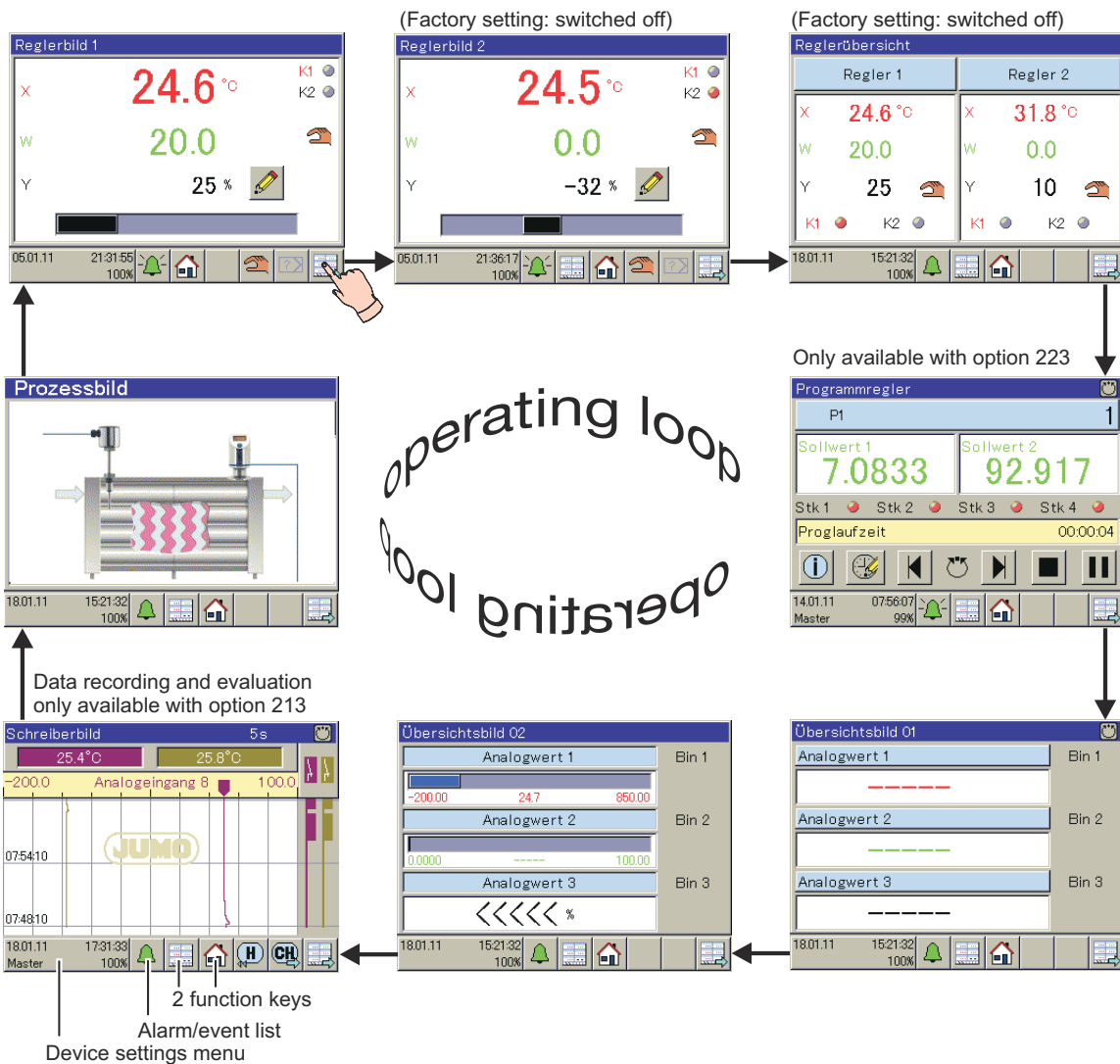
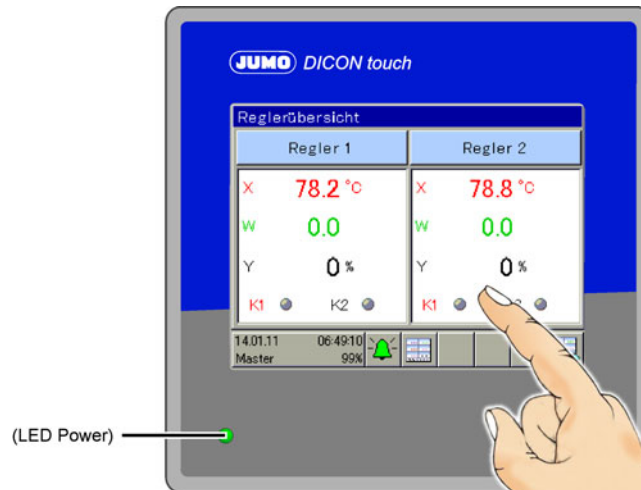

JUMO GmbH & Co. KG

Delivery address: Mackenrodtstraße 14
36039 Fulda, Germany
Postal address: 36035 Fulda, Germany
Phone: +49 661 6003-0
Fax: +49 661 6003-607
E-mail: mail@jumo.net
Internet: www.jumo.net

JUMO Instrument Co. Ltd.

JUMO House
Temple Bank, Riverway
Harlow, Essex CM20 2DY, UK
Phone: +44 1279 635533
Fax: +44 1279 635262
E-mail: sales@jumo.co.uk
Internet: www.jumo.co.uk

JUMO Process Control, Inc.

6733 Myers Road
East Syracuse, NY 13057, USA
Phone: 315-437-5866
1-800-554-5866
Fax: 315-437-5860
E-mail: info.us@jumo.net
Internet: www.jumousa.com



Controller parameters

The parameters and their meanings are listed in the table. Some parameters may be missing or meaningless for a particular type of controller. Three-state controllers have two controller structures that can be parameterized differently for "heating" and "cooling." Four parameter blocks can be managed for both of the controller channels.

Parameters	Value range	Factory setting	Meaning
Proportional band Xp1	0 to 9999 digits	0 digits	Size of the proportional band The controller structure has no effect at 0! In the case of a continuous controller, Xp1 and Xp2 must be > 0
Proportional band Xp2	0 to 9999 digits	0 digits	
Derivative time Tv1	0 to 9999 s	80 s	Influences the differential component of the controller output signal
Derivative time Tv2	0 to 9999 s	80 s	
Reset time Tn1	0 to 9999 s	350 s	Influences the integral component of the controller output signal
Reset time Tn2	0 to 9999 s	350 s	
Cycle time Cy1	0 to 999.9 s	20.0 s	When using a switched output, the cycle time should be chosen so that the energy supply to the process is as continuous as possible without overloading the switching elements
Cycle time Cy2	0 to 999.9 s	20.0 s	
Contact spacing Xsh	0 to 999.9 digits	0.0 digits	Spacing between the two control contacts for three-state controllers, three-state modulating controllers, and continuous controllers with integrated position controller
Switching differential Xd1	0 to 999.9 digits	1.0 digit	Hysteresis for switching controllers with proportional band = 0
Switching differential Xd2	0 to 999.9 digits	1.0 digit	
Actuator time TT	5 to 3000 s	60 s	Used run time range of the control valve for three-state modulating controllers
Working point Y0	-100 to +100 %	0 %	The output level for P and PD controllers (if x = w then y = Y0)
Output level limits Y1	0 to 100 %	100 %	The maximum limit for the output level
Output value limits Y2	-100 to +100 %	-100 %	The minimum limit for the output level
Minimum relay ON time Tk1	0.000 to 60.00 s	0.000 s	Limits the frequency of switching for switched outputs
Minimum relay ON time Tk2	0.000 to 60.00 s	0.000 s	

JUMO GmbH & Co. KG
 Delivery address: Mackenrodtstraße 14
 36039 Fulda, Germany
 Postal address: 36035 Fulda, Germany
 Phone: +49 661 6003-0
 Fax: +49 661 6003-607
 E-mail: mail@jumo.net
 Internet: www.jumo.net

JUMO Instrument Co. Ltd.
 JUMO House
 Temple Bank, Riverway
 Harlow, Essex CM20 2DY, UK
 Phone: +44 1279 635533
 Fax: +44 1279 635262
 E-mail: sales@jumo.co.uk
 Internet: www.jumo.co.uk

JUMO Process Control, Inc.
 6733 Myers Road
 East Syracuse, NY 13057, USA
 Phone: 315-437-5866
 1-800-554-5866
 Fax: 315-437-5860
 E-mail: info.us@jumo.net
 Internet: www.jumousa.com



Technical data

Analog inputs

General

Standard number	Two universal analog inputs
Optional number	Two additional universal analog inputs via optional boards
A/D converter	Dynamic resolution up to 16-bit

Thermocouples

Description	Standard	Measuring range	Measuring accuracy ^a	Ambient temperature influence
Fe-CuNi "L"	DIN EN 60584	-200 to +900 °C	≤ 0.25 %	≤ 100 ppm/K
Fe-CuNi "J"	DIN EN 60584	-200 to +1200 °C	≤ 0.25 %	≤ 100 ppm/K
Cu-CuNi "U"		-200 to +600 °C	≤ 0.25 % from -150 °C	≤ 100 ppm/K
Cu-CuNi "T"	DIN EN 60584	-200 to +400 °C	≤ 0.25 % from -150 °C	≤ 100 ppm/K
NiCr-Ni "K"	DIN EN 60584	-200 to +1372 °C	≤ 0.25 %	≤ 100 ppm/K
NiCr-CuNi "E"		-200 to +1000 °C	≤ 0.25 % from -80 °C	≤ 100 ppm/K
NiCrSi-NiSi "N"	DIN EN 60584	-100 to +1300 °C	≤ 0.25 %	≤ 100 ppm/K
Pt10Rh-Pt "S"	DIN EN 60584	-50 to 1768 °C	≤ 0.25 %	≤ 100 ppm/K
Pt13Rh-Pt "R"	DIN EN 60584	-50 to 1768 °C	≤ 0.25 %	≤ 100 ppm/K
Pt30Rh-Pt6Rh "B"	DIN EN 60584	0 to 1820 °C	≤ 0.25 % from 300 °C	≤ 100 ppm/K
W5Re-W26Re "C"		0 to 2320 °C	≤ 0.25 % from 500 °C	≤ 100 ppm/K
W3Re-W25Re "D"		0 to 2495 °C	≤ 0.25 % from 500 °C	≤ 100 ppm/K
Chromel®-Copel	GOST R 8.585-2001	-200 to +800 °C	≤ 0.25 % from -80 °C	≤ 100 ppm/K
Chromel®-Alumel®	GOST R 8.585-2001	-200 to +1372 °C	≤ 0.25 % from -80 °C	≤ 100 ppm/K
PLII (Platinel II)		0 to 1395 °C	≤ 0.25 %	≤ 100 ppm/K
Fe-CuNi "L"	GOST	-200 to +800 °C	≤ 0.25 %	≤ 100 ppm/K
Smallest measuring span		Type L, J, U, T, K, E, N, Chromel®-Alumel®, PL II; 100 K Type S, R, B, D, C, W3Re/W26Re, Chromel®-Copel: 500 K		
Measuring range start/end		Freely programmable within the limits in steps of 0.1 K		
Cold junction	GOST R	Pt100 internal, thermostat constant or external temperature probe		
Reference point accuracy (internal)		± 1 K		
Reference point temperature (external)		Adjustable from 0 to +100 °C		
Sampling cycle		Controller 1(2): 150 ms in total		
Input filter		Digital filter, 2nd order; filter constant can be set from 0 to 100 s		
Galvanic isolation		See "Electrical data" on page 5 and "Overview of the galvanic isolation" on page 16		
Resolution		> 14-bit		
Special features		Also programmable in °F		

^a The accuracy values refer to the maximum measuring range. Smaller measuring ranges lead to reduced linearization accuracy.

JUMO GmbH & Co. KG
 Delivery address: Mackenrodtstraße 14
 36039 Fulda, Germany
 Postal address: 36035 Fulda, Germany
 Phone: +49 661 6003-0
 Fax: +49 661 6003-607
 E-mail: mail@jumo.net
 Internet: www.jumo.net

JUMO Instrument Co. Ltd.
 JUMO House
 Temple Bank, Riverway
 Harlow, Essex CM20 2DY, UK
 Phone: +44 1279 635533
 Fax: +44 1279 635262
 E-mail: sales@jumo.co.uk
 Internet: www.jumo.co.uk

JUMO Process Control, Inc.
 6733 Myers Road
 East Syracuse, NY 13057, USA
 Phone: 315-437-5866
 1-800-554-5866
 Fax: 315-437-5860
 E-mail: info.us@jumo.net
 Internet: www.jumousa.com



RTD temperature probe

Description	Standard	Measuring range	Measuring accuracy ^a	Ambient temperature influence
Pt50 Two-wire circuit Three-wire circuit	DIN EN 60751	-200 to +850 °C	≤ 0.1 %	≤ 50 ppm/K
Pt100 Two-wire circuit Three-wire circuit	DIN EN 60751	-200 to +850 °C	≤ 0.05 %	≤ 50 ppm/K
Pt500 Two-wire circuit Three-wire circuit	DIN EN 60751	-200 to +850 °C	≤ 0.1 %	≤ 50 ppm/K
Pt1000 Two-wire circuit Three-wire circuit	DIN EN 60751	-200 to +850 °C	≤ 0.1 %	≤ 50 ppm/K
Ni100 Two-wire circuit Three-wire circuit	DIN EN 43760	-60 to +250 °C	≤ 0.1 %	≤ 50 ppm/K
KTY11-6 Two-wire circuit		-50 to +150 °C	≤ 1 %	≤ 50 ppm/K
Pt50 Two-wire circuit Three-wire circuit	GOST 6651-99	-200 to +850 °C	≤ 0.1 %	≤ 50 ppm/K
Pt100 Two-wire circuit Three-wire circuit	GOST 6651-94	-200 to +850 °C	≤ 0.08 % ≤ 0.05 %	≤ 50 ppm/K
Cu50 Two-wire circuit Three-wire circuit	GOST 6651-94	-50 to +200 °C	≤ 0.05 %	≤ 50 ppm/K
Cu100 Two-wire circuit Three-wire circuit	GOST 6651-94	-50 to +200 °C	≤ 0.36 % ≤ 0.24 %	≤ 50 ppm/K
Smallest measuring span		15 K		
Measuring current		Pt100 approx. 250 µA, Pt1000 approx. 100 µA		
Sensor lead resistance		Max. 10 Ω per cable for two-wire and three-wire circuits		
Lead compensation		Not required for three-wire circuit. For a two-wire circuit, the lead resistance can be compensated for in the software by correcting the process value.		
Measuring range start/end		Freely programmable within the limits in steps of 0.1 K		
Sampling cycle		Controller 1(2): 150 ms in total		
Input filter		Digital filter, 2nd order; filter time constant can be set from 0 to 100 s		
Galvanic isolation		See "Electrical data" on page eight and "Overview of the galvanic isolation" on page 16		
Resolution		> 14-bit		
Special features		Also programmable in °F		

^a The accuracy values refer to the maximum measuring range. Smaller measuring ranges lead to reduced linearization accuracy.

JUMO GmbH & Co. KG
 Delivery address: Mackenrodtstraße 14
 36039 Fulda, Germany
 Postal address: 36035 Fulda, Germany
 Phone: +49 661 6003-0
 Fax: +49 661 6003-607
 E-mail: mail@jumo.net
 Internet: www.jumo.net

JUMO Instrument Co. Ltd.
 JUMO House
 Temple Bank, Riverway
 Harlow, Essex CM20 2DY, UK
 Phone: +44 1279 635533
 Fax: +44 1279 635262
 E-mail: sales@jumo.co.uk
 Internet: www.jumo.co.uk

JUMO Process Control, Inc.
 6733 Myers Road
 East Syracuse, NY 13057, USA
 Phone: 315-437-5866
 1-800-554-5866
 Fax: 315-437-5860
 E-mail: info.us@jumo.net
 Internet: www.jumousa.com



Standard signals

Description	Measuring range	Measuring accuracy ^a	Ambient temperature influence
Freely scalable voltage Input resistance $R_E > 500 \text{ k}\Omega$ Input resistance $R_E > 100 \text{ k}\Omega$	DC 0(2) to 10 V DC 0 to 1 V	$\leq 0.1 \%$	$\leq 100 \text{ ppm/K}$
Smallest measuring span	5 mV		
Measuring range start/end	Freely programmable within the limits in steps of 0.01 mV		
Current (voltage drop $\leq 2 \text{ V}$), freely scalable	DC 0(4) to 20 mA	$\leq 0.1 \%$	$\leq 100 \text{ ppm/K}$
Smallest measuring span	0.5 mA		
Measuring range start/end	Freely programmable within the limits in steps of 0.01 mA		
Underrange/overrange	According to NAMUR NE 43		
Sampling cycle	Controller 1(2): 150 ms in total		
Input filter	Digital filter, 2nd order; filter constant can be set from 0 to 10.0 s		
Galvanic isolation	See "Electrical data" on page eight and "Overview of the galvanic isolation" on page 16		
Resolution	> 14-bit		
Resistance transmitter	Min. 100 Ω , max. 10 k Ω	$\leq 0.5 \%$ ^b	$\leq 100 \text{ ppm/K}$
Connection type	Resistance transmitter: three-wire circuit		
Smallest measuring span	60 Ω		
Sensor lead resistance	Max. 10 Ω per cable for two-wire and three-wire circuits		
Resistance values	Freely programmable within the limits in steps of 0.1 Ω		
Sampling cycle	Controller 1(2): 150 ms in total		
Input filter	Digital filter, 2nd order; filter constant can be set from 0 to 100 s		
Galvanic isolation	See "Electrical data" on page eight and "Overview of the galvanic isolation" on page 16		
Resolution	> 14-bit		

^a The accuracy values refer to the maximum measuring range. Smaller measuring ranges lead to reduced linearization accuracy.

^b The accuracy values refer to the maximum measuring range (initial resistance R_a + loop resistance R_S + end resistance R_e).

Measuring circuit monitoring

In the event of a fault, the outputs change to defined statuses (configurable).

Measuring probe	Overrange/underrange	Probe/cable short circuit	Probe/cable break
Thermocouple	Is detected	Is not detected	Is detected
RTD temperature probe	Is detected	Is detected	Is detected
Voltage			
2 to 10 V	Is detected	Is detected	Is detected
0 to 10 V	Is detected	Is not detected	Is not detected
0 to 1 V	Is detected	Is not detected	Is not detected
Current			
4 to 20 mA	Is detected	Is detected	Is detected
0 to 20 mA	Is detected	Is not detected	Is not detected
Resistance transmitter	Is not detected	Is not detected	Is detected

Digital inputs

Standard number	7
Control	Potential-free contact

JUMO GmbH & Co. KG
 Delivery address: Mackenrodtstraße 14
 36039 Fulda, Germany
 Postal address: 36035 Fulda, Germany
 Phone: +49 661 6003-0
 Fax: +49 661 6003-607
 E-mail: mail@jumo.net
 Internet: www.jumo.net

JUMO Instrument Co. Ltd.
 JUMO House
 Temple Bank, Riverway
 Harlow, Essex CM20 2DY, UK
 Phone: +44 1279 635533
 Fax: +44 1279 635262
 E-mail: sales@jumo.co.uk
 Internet: www.jumo.co.uk

JUMO Process Control, Inc.
 6733 Myers Road
 East Syracuse, NY 13057, USA
 Phone: 315-437-5866
 1-800-554-5866
 Fax: 315-437-5860
 E-mail: info.us@jumo.net
 Internet: www.jumousa.com



Analog outputs

Per optional board (OUT3, 5, 7, 9, and OUT11 are possible)

1 analog output (configurable) 12-bit resolution Voltage DC 0(2) to 10 V Current DC 0(4) to 20 mA	Load resistance R_{Last} $\geq 500 \Omega$ $\leq 500 \Omega$	Accuracy $\pm 0.25 \%$ $\pm 0.25 \%$	Ambient temperature influence $\pm 100 \text{ ppm/K}$ $\pm 100 \text{ ppm/K}$
------------------------------------------------------------------------------------------------------------	----------------------------------------------------------------------	--------------------------------------------	-------------------------------------------------------------------------------------

Digital outputs

Standard

Two relay outputs (changeover contact) Switching capacity Contact life	3 A at AC 230 V, resistive load 150,000 operations at rated load, 350,000 operations at 1 A
------------------------------------------------------------------------------	------------------------------------------------------------------------------------------------

Per optional board

1 relay output (changeover contact) Switching capacity Contact life	3 A at AC 230 V resistive load 350,000 operations at rated load, 750,000 operations at 1 A
2 relay outputs (N/O contact) ^a Switching capacity Contact life	3 A at AC 230 V, resistive load 350,000 operations at rated load, 900,000 operations at 1 A
1 solid-state relay Switching capacity Protection circuitry	1 A at 230 V varistor
1 logic output (supply voltage for transmitter)	DC 0/22 V max. 30 mA (short-circuit proof)
2 logic outputs	DC 0/12 V max. 20 mA (short-circuit proof, not galvanically isolated)
2 PhotoMOS [®] relays ^b	DC 50 V, max. 200 mA, (galvanically isolated from each other, not short-circuit proof) AC 35 V, max. 200 mA, (galvanically isolated from each other, not short-circuit proof)

^a A combination of mains-voltage and low-voltage circuits in a two-way N/O contact option is not permitted

^b PhotoMOS is a registered trademark of Panasonic Electric Works Co. Ltd.

Controllers

Controller types	Inverse/direct two-state controller, three-state controller, three-state modulating controller, inverse/direct continuous controller, continuous controller with integrated position controller
Controller structures	P, PD, PI, PID
Sampling rate	150 ms
Parameter blocks	Four parameter blocks per controller

Screen

Resolution, size	320 × 240 pixels, 3.5"
Type, number of colors	TFT color screen, 256 colors
Brightness setting	Adjustable on the device
Device operation	Via resistive touchscreen
Screensaver	Via waiting period or control signal

JUMO GmbH & Co. KG
 Delivery address: Mackenrodtstraße 14
 36039 Fulda, Germany
 Postal address: 36035 Fulda, Germany
 Phone: +49 661 6003-0
 Fax: +49 661 6003-607
 E-mail: mail@jumo.net
 Internet: www.jumo.net

JUMO Instrument Co. Ltd.
 JUMO House
 Temple Bank, Riverway
 Harlow, Essex CM20 2DY, UK
 Phone: +44 1279 635533
 Fax: +44 1279 635262
 E-mail: sales@jumo.co.uk
 Internet: www.jumo.co.uk

JUMO Process Control, Inc.
 6733 Myers Road
 East Syracuse, NY 13057, USA
 Phone: 315-437-5866
 1-800-554-5866
 Fax: 315-437-5860
 E-mail: info.us@jumo.net
 Internet: www.jumousa.com



Electrical data

Supply voltage Connection Voltage	At the back via screw terminals AC/DC 20 to 30 V, 48 to 63 Hz or AC 110 to 240 V +10/-15 %, 48 to 63 Hz
Power consumption	At supply voltage 230 V: max. 38.1 VA/11.5 W At supply voltage 24 V: max. 21.9 VA/11.5 W
Inputs and outputs Connection Conductor cross section	At the back via screw terminals Max. 2.5 mm ² , wire or strand with end sleeve
Electrical safety	According to DIN EN 61010-1 Overvoltage category III, pollution degree 2
Electromagnetic compatibility Interference emission Interference immunity	According to DIN EN 61326-1 Class B Industrial requirement

Environmental influences

Ambient/storage temperature range	-5 to +55 °C / -30 to +70 °C
Resistance to climatic conditions	Humidity 3K3 (DIN EN 61721-3-3 with extended temperature range), rel. humidity ≤ 95 % annual average, no condensation
Electromagnetic compatibility Interference emission Interference immunity	According to DIN EN 61326-1 Class B Industrial requirement

Case

Case type	Plastic front frame with metal case barrel
Front frame dimensions	96 mm × 96 mm
Panel cut-out	92 ^{+0.8} mm × 92 ^{+0.8} mm according to DIN IEC 61554
Close mounting	Spacing between the panel cut-outs, min. 35 mm horizontally and min. 80 mm vertically
Panel thickness	Max. 5 mm
Depth behind panel	Max. 130 mm
Mounting	Four mounting brackets
Operating position (including the viewing angle of the TFT color screen)	Any Horizontal ±65°, vertical +40 to -65°
Protection type	Front IP66, rear IP20, according to DIN EN 60529
Weight (fully fitted)	Approx. 1000 g

Approvals / approval marks

Approval mark	Testing agency	Certificate/certification number	Inspection basis	Valid for
GL - hardware GL - software	Germanischer Lloyd	Approval submitted	Environmental Category C EMC 1	All devices
c UL us	Underwriters Laboratories	Approval submitted	UL 61010-1	All devices
GOST		Approval submitted		All devices

JUMO GmbH & Co. KG
 Delivery address: Mackenrodtstraße 14
 36039 Fulda, Germany
 Postal address: 36035 Fulda, Germany
 Phone: +49 661 6003-0
 Fax: +49 661 6003-607
 E-mail: mail@jumo.net
 Internet: www.jumo.net

JUMO Instrument Co. Ltd.
 JUMO House
 Temple Bank, Riverway
 Harlow, Essex CM20 2DY, UK
 Phone: +44 1279 635533
 Fax: +44 1279 635262
 E-mail: sales@jumo.co.uk
 Internet: www.jumo.co.uk

JUMO Process Control, Inc.
 6733 Myers Road
 East Syracuse, NY 13057, USA
 Phone: 315-437-5866
 1-800-554-5866
 Fax: 315-437-5860
 E-mail: info.us@jumo.net
 Internet: www.jumousa.com



Connection elements

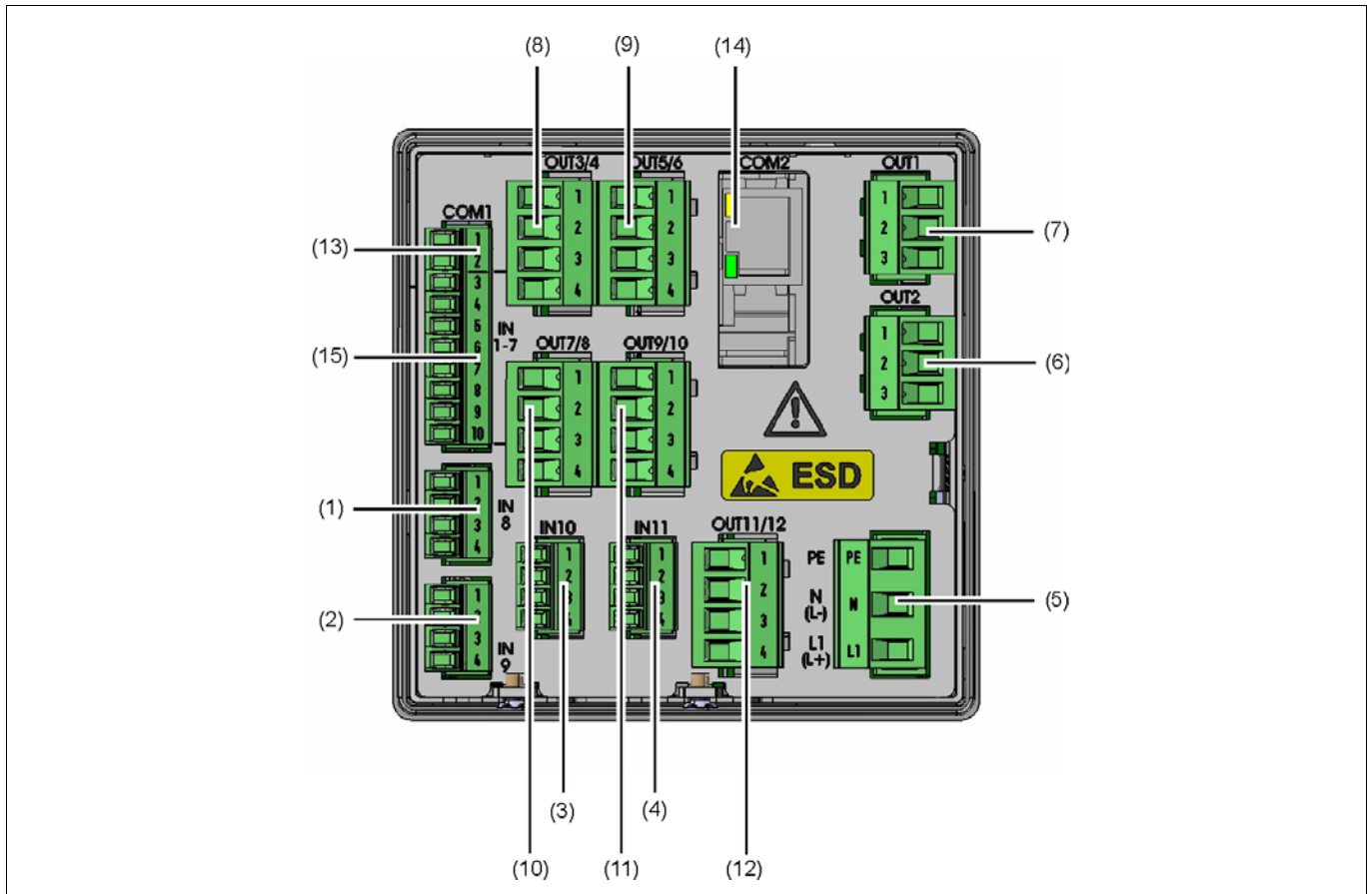

- | | |
|----------------------------------------------------------------------------------------|------------------------------------------|
| (1) Analog input IN8 | (2) Analog input IN9 |
| (3) Expansion slot for analog input IN10 | (4) Expansion slot for analog input IN11 |
| (5) Supply voltage
AC 240 V +10/-15 %, 48 to 63 Hz
AC/DC 20 to 30 V, 48 to 63 Hz | (6) Relay output OUT2 |
| (7) Relay output OUT1 | (8) Expansion slot for outputs OUT3/4 |
| (9) Expansion slot for outputs OUT5/6 | (10) Expansion slot for outputs OUT7/8 |
| (11) Expansion slot for outputs OUT9/10 | (12) Expansion slot for outputs OUT11/12 |
| (13) COM1 interface RS485 | (14) Expansion slot for COM2 interface |
| (15) Digital inputs IN1 to 7 | |

JUMO GmbH & Co. KG
 Delivery address: Mackenrodtstraße 14
 36039 Fulda, Germany
 Postal address: 36035 Fulda, Germany
 Phone: +49 661 6003-0
 Fax: +49 661 6003-607
 E-mail: mail@jumo.net
 Internet: www.jumo.net

JUMO Instrument Co. Ltd.
 JUMO House
 Temple Bank, Riverway
 Harlow, Essex CM20 2DY, UK
 Phone: +44 1279 635533
 Fax: +44 1279 635262
 E-mail: sales@jumo.co.uk
 Internet: www.jumo.co.uk

JUMO Process Control, Inc.
 6733 Myers Road
 East Syracuse, NY 13057, USA
 Phone: 315-437-5866
 1-800-554-5866
 Fax: 315-437-5860
 E-mail: info.us@jumo.net
 Internet: www.jumousa.com



Galvanic isolation

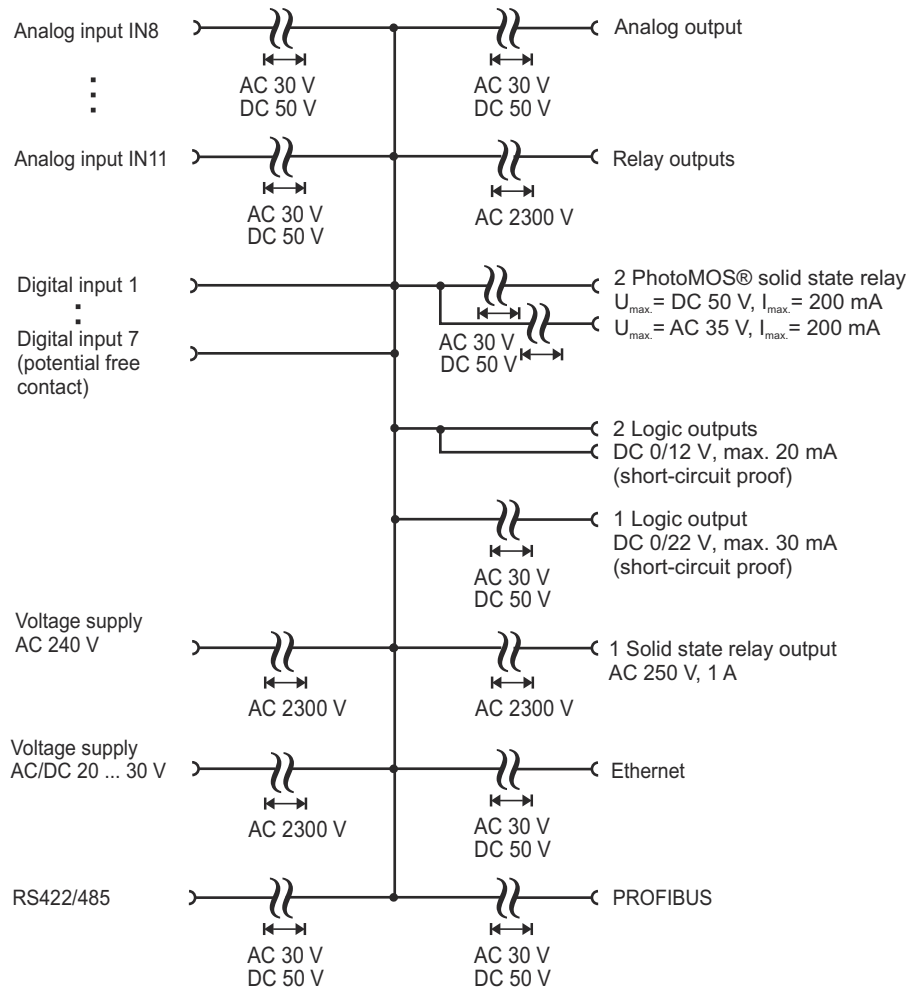

JUMO GmbH & Co. KG
 Delivery address: Mackenrodtstraße 14
 36039 Fulda, Germany
 Postal address: 36035 Fulda, Germany
 Phone: +49 661 6003-0
 Fax: +49 661 6003-607
 E-mail: mail@jumo.net
 Internet: www.jumo.net

JUMO Instrument Co. Ltd.
 JUMO House
 Temple Bank, Riverway
 Harlow, Essex CM20 2DY, UK
 Phone: +44 1279 635533
 Fax: +44 1279 635262
 E-mail: sales@jumo.co.uk
 Internet: www.jumo.co.uk

JUMO Process Control, Inc.
 6733 Myers Road
 East Syracuse, NY 13057, USA
 Phone: 315-437-5866
 1-800-554-5866
 Fax: 315-437-5860
 E-mail: info.us@jumo.net
 Internet: www.jumousa.com



Connection diagram

The connection diagram included in the data sheet provides initial information about the connection options. Only use the installation instructions or the operating manual for the electrical connection. The know-how and the correct technical implementation of the safety warnings/instructions contained in these documents are the prerequisite for the installation, electrical connection, and initial start as well as for the safety during operation.

Analog inputs

Input IN8, IN9 as standard

Two analog inputs can be added to input (IN10), (IN11) optional boards

Connection	(Connection element) Input	Symbol and terminal designation
Thermocouple	(1) IN8 (2) IN9 (3) IN10 (4) IN11	
RTD temperature probe Two-wire circuit		
RTD temperature probe Three-wire circuit		
Voltage DC 0(2) to 10 V		
Voltage DC 0 to 1 V		
Current DC 0(4) to 20 mA		
Resistance transmitter A = Start E = End S = Slider		

Analog outputs

One analog output can be added to output OUT 3/4 to 11/12 using optional boards

Connection	(Connection element) Input	Symbol and terminal designation
One analog output DC 0/2 to 10 V or DC 0/4 to 20 mA (configurable)	(8) OUT3/4 (9) OUT5/6 (10) OUT7/8 (11) OUT9/10 (12) OUT11/12	

JUMO GmbH & Co. KG
 Delivery address: Mackenrodtstraße 14
 36039 Fulda, Germany
 Postal address: 36035 Fulda, Germany
 Phone: +49 661 6003-0
 Fax: +49 661 6003-607
 E-mail: mail@jumo.net
 Internet: www.jumo.net

JUMO Instrument Co. Ltd.
 JUMO House
 Temple Bank, Riverway
 Harlow, Essex CM20 2DY, UK
 Phone: +44 1279 635533
 Fax: +44 1279 635262
 E-mail: sales@jumo.co.uk
 Internet: www.jumo.co.uk

JUMO Process Control, Inc.
 6733 Myers Road
 East Syracuse, NY 13057, USA
 Phone: 315-437-5866
 1-800-554-5866
 Fax: 315-437-5860
 E-mail: info.us@jumo.net
 Internet: www.jumousa.com



Digital inputs

Input IN1 to 7 as standard (cannot be extended)

Connection	(Connection element) Input	Symbol and terminal designation
Digital input, potential-free contact as standard	(15) IN1 to 7	

Digital outputs

OUT1 and OUT2 as standard

The controller is fitted with two relay outputs (changeover contacts) as standard.

Connection	(Connection element) Output	Symbol and terminal designation
Relay output (changeover contact)	(6) OUT2 (7) OUT1	

JUMO GmbH & Co. KG
 Delivery address: Mackenrodtstraße 14
 36039 Fulda, Germany
 Postal address: 36035 Fulda, Germany
 Phone: +49 661 6003-0
 Fax: +49 661 6003-607
 E-mail: mail@jumo.net
 Internet: www.jumo.net

JUMO Instrument Co. Ltd.
 JUMO House
 Temple Bank, Riverway
 Harlow, Essex CM20 2DY, UK
 Phone: +44 1279 635533
 Fax: +44 1279 635262
 E-mail: sales@jumo.co.uk
 Internet: www.jumo.co.uk

JUMO Process Control, Inc.
 6733 Myers Road
 East Syracuse, NY 13057, USA
 Phone: 315-437-5866
 1-800-554-5866
 Fax: 315-437-5860
 E-mail: info.us@jumo.net
 Internet: www.jumousa.com



Outputs OUT 3/4 to 11/12 can be expanded using the following optional boards

Connection	(Connection element) Output	Symbol and terminal designation
1 relay output (changeover contact)	(8) OUT3/4 (9) OUT5/6 (10) OUT7/8 (11) OUT9/10 (12) OUT11/12	
2 relay outputs (N/O contact)		
1 solid-state relay AC 230 V, 1 A		
1 logic output DC 0/22 V max. 30 mA (short-circuit proof)		+ ———— 1 U_x, I_x - ———— 2
2 logic outputs DC 0/12 V max. 20 mA (short-circuit proof, not galvanically isolated from each other)		+ ———— 1 U_x, I_x - ———— 2 + ———— 3 U_x, I_x - ———— 4
2 PhotoMOS® relays ^a max. DC 50 V, 200 mA max. AC 35 V, 200 mA (galvanically isolated)		

^a PhotoMOS is a registered trademark of Panasonic Electric Works Co. Ltd.

JUMO GmbH & Co. KG
 Delivery address: Mackenrodtstraße 14
 36039 Fulda, Germany
 Postal address: 36035 Fulda, Germany
 Phone: +49 661 6003-0
 Fax: +49 661 6003-607
 E-mail: mail@jumo.net
 Internet: www.jumo.net



JUMO Instrument Co. Ltd.
 JUMO House
 Temple Bank, Riverway
 Harlow, Essex CM20 2DY, UK
 Phone: +44 1279 635533
 Fax: +44 1279 635262
 E-mail: sales@jumo.co.uk
 Internet: www.jumo.co.uk

JUMO Process Control, Inc.
 6733 Myers Road
 East Syracuse, NY 13057, USA
 Phone: 315-437-5866
 1-800-554-5866
 Fax: 315-437-5860
 E-mail: info.us@jumo.net
 Internet: www.jumousa.com



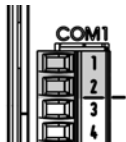

Interfaces

USB device, USB host and COM1 interfaces as standard

Connection	(Connection element)	Symbol and terminal designation				
USB device interface (setup)	(21)					
USB host (firmware update)	(20)					
COM1 serial interface RS485 (galvanically isolated)	(13)	 <table style="display: inline-table; vertical-align: middle;"> <tr> <td>1 TxD+/RxD+</td> <td>Transmission/received data +</td> </tr> <tr> <td>2 TxD-/RxD-</td> <td>Transmission/received data -</td> </tr> </table>	1 TxD+/RxD+	Transmission/received data +	2 TxD-/RxD-	Transmission/received data -
1 TxD+/RxD+	Transmission/received data +					
2 TxD-/RxD-	Transmission/received data -					

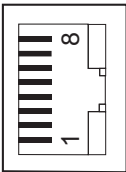
COM2 interface can be expanded using optional boards

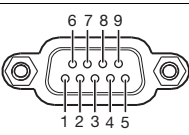
Connection	(Connection element)	Symbol and terminal designation								
Ethernet	(14)	 <table style="display: inline-table; vertical-align: middle;"> <tr> <td>1 TX+</td> <td>Transmission data +</td> </tr> <tr> <td>2 TX-</td> <td>Transmission data -</td> </tr> <tr> <td>3 RX+</td> <td>Received data +</td> </tr> <tr> <td>6 RX-</td> <td>Received data -</td> </tr> </table>	1 TX+	Transmission data +	2 TX-	Transmission data -	3 RX+	Received data +	6 RX-	Received data -
1 TX+	Transmission data +									
2 TX-	Transmission data -									
3 RX+	Received data +									
6 RX-	Received data -									
Serial interface RS422 (galvanically isolated)		 <table style="display: inline-table; vertical-align: middle;"> <tr> <td>1 RxD+</td> <td>Received data +</td> </tr> <tr> <td>2 RxD-</td> <td>Received data -</td> </tr> <tr> <td>3 TxD+</td> <td>Transmission data +</td> </tr> <tr> <td>4 TxD-</td> <td>Transmission data -</td> </tr> </table>	1 RxD+	Received data +	2 RxD-	Received data -	3 TxD+	Transmission data +	4 TxD-	Transmission data -
1 RxD+	Received data +									
2 RxD-	Received data -									
3 TxD+	Transmission data +									
4 TxD-	Transmission data -									
Serial interface RS485 (galvanically isolated)		 <table style="display: inline-table; vertical-align: middle;"> <tr> <td>3 TxD+/RxD+</td> <td>Transmission/received data +</td> </tr> <tr> <td>4 TxD-/RxD-</td> <td>Transmission/received data -</td> </tr> </table>	3 TxD+/RxD+	Transmission/received data +	4 TxD-/RxD-	Transmission/received data -				
3 TxD+/RxD+	Transmission/received data +									
4 TxD-/RxD-	Transmission/received data -									
PROFIBUS-DP		 <table style="display: inline-table; vertical-align: middle;"> <tr> <td>3 RxD/TxD-P (B)</td> <td>Transmission/received data +</td> </tr> <tr> <td>5 DGND</td> <td>Ground</td> </tr> <tr> <td>6 VP (+5 V)</td> <td>Voltage supply</td> </tr> <tr> <td>8 RxD/TxD-N (A)</td> <td>Transmission/received data -</td> </tr> </table>	3 RxD/TxD-P (B)	Transmission/received data +	5 DGND	Ground	6 VP (+5 V)	Voltage supply	8 RxD/TxD-N (A)	Transmission/received data -
3 RxD/TxD-P (B)	Transmission/received data +									
5 DGND	Ground									
6 VP (+5 V)	Voltage supply									
8 RxD/TxD-N (A)	Transmission/received data -									

JUMO GmbH & Co. KG
 Delivery address: Mackenrodtstraße 14
 36039 Fulda, Germany
 Postal address: 36035 Fulda, Germany
 Phone: +49 661 6003-0
 Fax: +49 661 6003-607
 E-mail: mail@jumo.net
 Internet: www.jumo.net

JUMO Instrument Co. Ltd.
 JUMO House
 Temple Bank, Riverway
 Harlow, Essex CM20 2DY, UK
 Phone: +44 1279 635533
 Fax: +44 1279 635262
 E-mail: sales@jumo.co.uk
 Internet: www.jumo.co.uk

JUMO Process Control, Inc.
 6733 Myers Road
 East Syracuse, NY 13057, USA
 Phone: 315-437-5866
 1-800-554-5866
 Fax: 315-437-5860
 E-mail: info.us@jumo.net
 Internet: www.jumousa.com



Dimensions

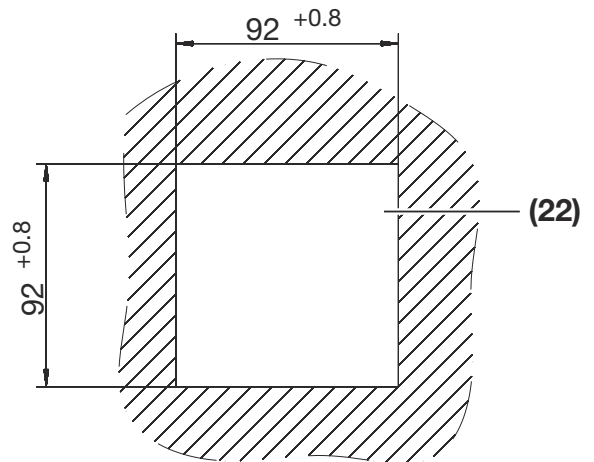
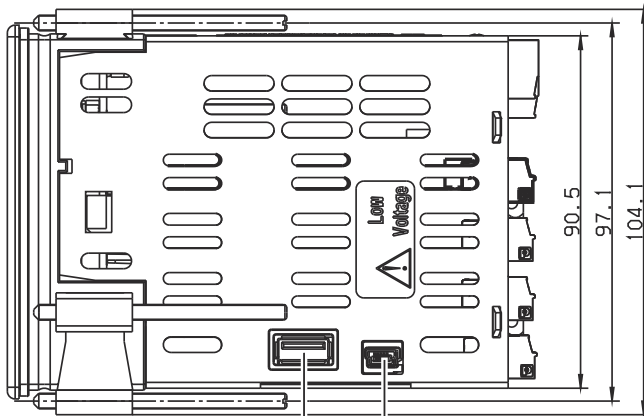
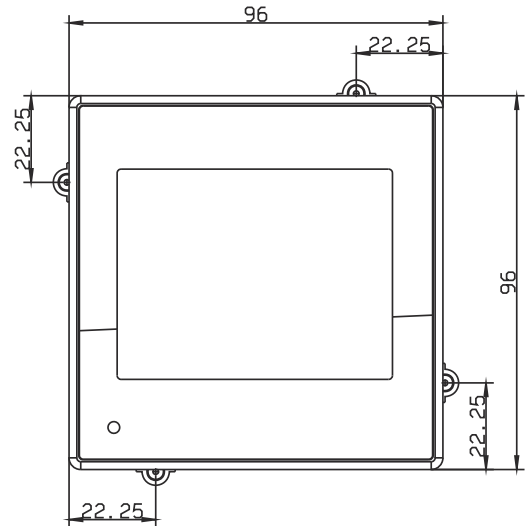
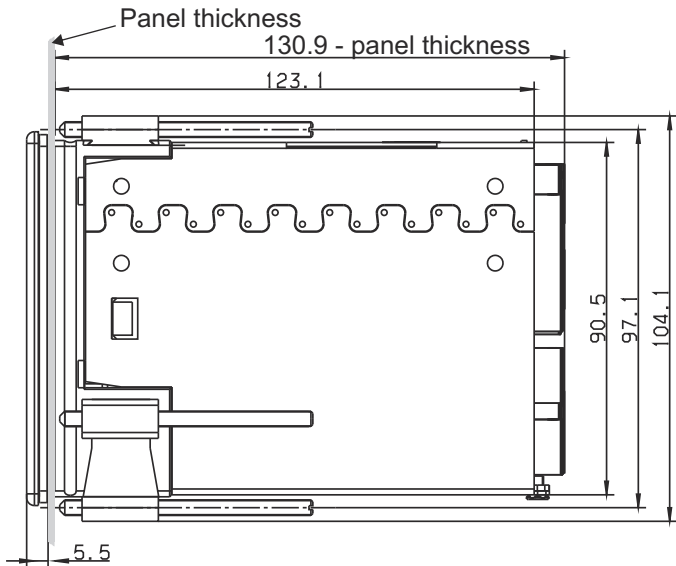

(20) (21)

- (20) USB host interface
- (22) Panel cut-out

- (21) USB device interface for setup

Scope of delivery

- 1 controller in the ordered version
- 1 operating manual B 703571.0
- 1 panel seal 4 retaining elements for panel installation

JUMO GmbH & Co. KG

Delivery address: Mackenrodtstraße 14
36039 Fulda, Germany
Postal address: 36035 Fulda, Germany
Phone: +49 661 6003-0
Fax: +49 661 6003-607
E-mail: mail@jumo.net
Internet: www.jumo.net

JUMO Instrument Co. Ltd.

JUMO House
Temple Bank, Riverway
Harlow, Essex CM20 2DY, UK
Phone: +44 1279 635533
Fax: +44 1279 635262
E-mail: sales@jumo.co.uk
Internet: www.jumo.co.uk

JUMO Process Control, Inc.

6733 Myers Road
East Syracuse, NY 13057, USA
Phone: 315-437-5866
1-800-554-5866
Fax: 315-437-5860
E-mail: info.us@jumo.net
Internet: www.jumousa.com



Order details

(1) Basic type	
703571	JUMO DICON touch - two-channel process and program controller with RS485 interface
(2) Version	
8	Standard with factory settings
9	Customer-specific configuration (specifications in plain text)
(3) National language of display texts	
01	German
02	English
03	French
(4) Input 3 (IN10)	
00	Not used
10	Analog input (universal)
(5) Input 4 (IN11)	
00	Not used
10	Analog input (universal)
(6) Output 3 (OUT3/4)	
00	None
11	1 relay (changeover contact)
12	2 relays (N/O contact)
13	1 solid-state relay 230 V, 1 A
14	1 logic output 0/22 V
15	2 logic outputs 0/12 V, 20 mA
16	1 analog output
17	2 PhotoMOS® relays ^a
(7) Output 4 (OUT5/6)	
00	None
11	1 relay (changeover contact)
12	2 relays (N/O contact)
13	1 solid-state relay 230 V, 1 A
14	1 logic output 0/22 V
15	2 logic outputs 0/12 V, 20 mA
16	1 analog output
17	2 PhotoMOS® relays
(8) Output 5 (OUT7/8)	
00	None
11	1 relay (changeover contact)
12	2 relays (N/O contact)
13	1 solid-state relay 230 V, 1 A
14	1 logic output 0/22 V
15	2 logic outputs 0/12 V, 20 mA
16	1 analog output
17	2 PhotoMOS® relays
(9) Output 6 (OUT9/10)	
00	None
11	1 relay (changeover contact)
12	2 relays (N/O contact)
13	1 solid-state relay 230 V, 1 A
14	1 logic output 0/22 V
15	2 logic outputs 0/12 V, 20 mA
16	1 analog output

JUMO GmbH & Co. KG
 Delivery address: Mackenrodtstraße 14
 36039 Fulda, Germany
 Postal address: 36035 Fulda, Germany
 Phone: +49 661 6003-0
 Fax: +49 661 6003-607
 E-mail: mail@jumo.net
 Internet: www.jumo.net

JUMO Instrument Co. Ltd.
 JUMO House
 Temple Bank, Riverway
 Harlow, Essex CM20 2DY, UK
 Phone: +44 1279 635533
 Fax: +44 1279 635262
 E-mail: sales@jumo.co.uk
 Internet: www.jumo.co.uk

JUMO Process Control, Inc.
 6733 Myers Road
 East Syracuse, NY 13057, USA
 Phone: 315-437-5866
 1-800-554-5866
 Fax: 315-437-5860
 E-mail: info.us@jumo.net
 Internet: www.jumousa.com



17	2 PhotoMOS® relays
(10) Output 7 (OUT11/12)	
00	None
11	1 relay (changeover contact)
12	2 relays (N/O contact)
13	1 solid-state relay 230 V, 1 A
14	1 logic output 0/22 V
15	2 logic outputs 0/12 V, 20 mA
16	1 analog output
17	2 PhotoMOS® relays
(11) Supply voltage	
23	AC 110 to 240 V +10/-15 %, 48 to 63 Hz
25	AC/DC 20 to 30 V, 48 to 63 Hz
(12) COM2 interface	
00	Not used
08	Ethernet
54	RS422/485 Modbus RTU
64	PROFIBUS-DP
(13) DIN-tested	
000	Without approval
056	With DIN approval
(14) GL-tested	
000	Without approval
062	With GL approval
(15) Extra codes	
000	Without extra code
213	Recording function
214	Math and logic module
223	Program controller

^a PhotoMOS is a registered trademark of Panasonic Electric Works Co. Ltd.

Order code (1) / (2) - (3) - (4) (5) - (6) (7) (8) (9) (10) - (11) - (12) / (13) , (14) , (15)
 Order example 703571 / X - X - X X - X X X X X - X - X / X , X , X ...^a

^a List extra codes in sequence, separated by commas.





JUMO GmbH & Co. KG
 Delivery address: Mackenrodtstraße 14
 36039 Fulda, Germany
 Postal address: 36035 Fulda, Germany
 Phone: +49 661 6003-0
 Fax: +49 661 6003-607
 E-mail: mail@jumo.net
 Internet: www.jumo.net

JUMO Instrument Co. Ltd.
 JUMO House
 Temple Bank, Riverway
 Harlow, Essex CM20 2DY, UK
 Phone: +44 1279 635533
 Fax: +44 1279 635262
 E-mail: sales@jumo.co.uk
 Internet: www.jumo.co.uk

JUMO Process Control, Inc.
 6733 Myers Road
 East Syracuse, NY 13057, USA
 Phone: 315-437-5866
 1-800-554-5866
 Fax: 315-437-5860
 E-mail: info.us@jumo.net
 Internet: www.jumousa.com

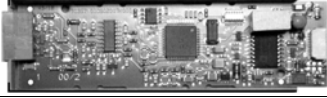

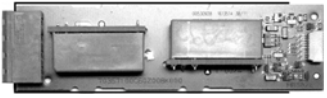
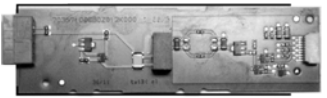
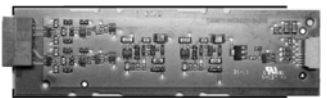
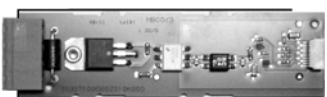
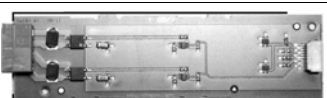
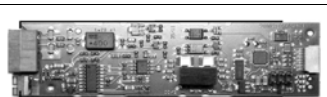
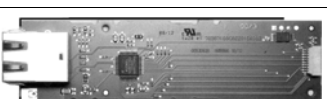
Accessories

Article		Part no.
Assembly groups for option slots:		
1 analog input (universal)		00581159
1 relay output (changeover contact)		00581160
2 relay outputs (N/O contact)		00581162
1 logic output DC 0/22 V max. 30 mA		00581165
2 logic outputs DC 0/12 V max. 20 mA		00581168
1 solid-state relay AC 230 V, 1 A		00581164
2 PhotoMOS® relays ^a DC 50 V, max. 200 mA, AC 35 V, max. 200 mA		00581171
1 analog output (universal)		00581169
Ethernet interface		00581174
Serial interface RS422/RS485		00581172
PROFIBUS-DP interface		00581173

^a PhotoMOS is a registered trademark of Panasonic Electric Works Co. Ltd.

General accessories

Article	Part no.
DVD with setup program and program editor	
USB cable A-connector mini B-connector 3 m	00506252